

## Equipment winding - unwinding

French Manufacturer of expandable airshafts - Safety chucks - Brakes - Spreader rolls

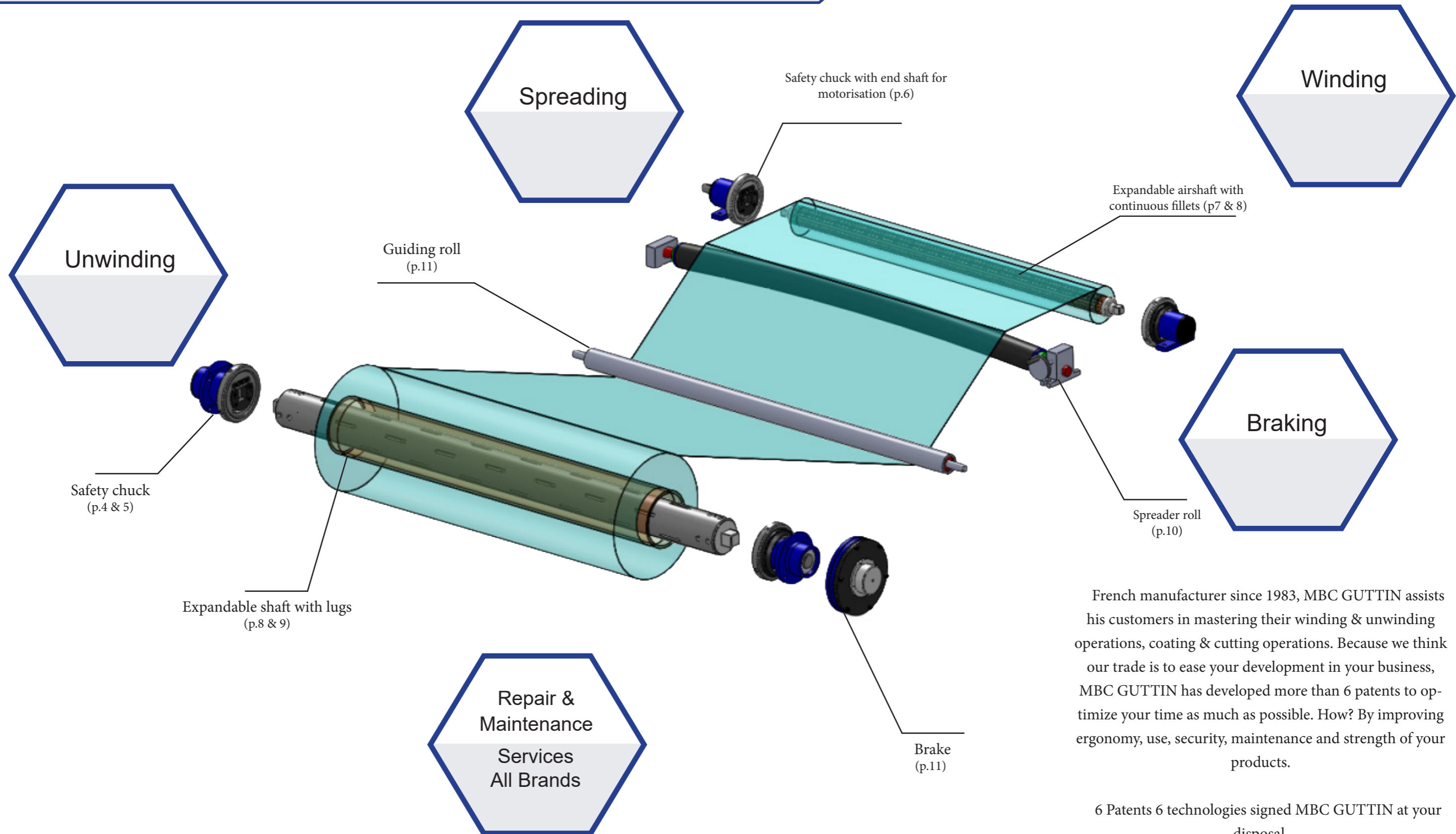

MECHANISM  
BLOCKING  
CONTROL



French manufacturer since 1983, MBC GUTTIN assists his customers in mastering their winding & unwinding operations, coating & cutting operations. Because we think our trade is to ease your development in your business, MBC GUTTIN has developed more than 6 patents to optimize your time as much as possible. How? By improving ergonomy, use, security, maintenance and strength of your products.

6 Patents 6 technologies signed MBC GUTTIN at your disposal.

# SAFETY CHUCKS

## Benefits

### Made in France

100 % steel

To be mounted instead any installation :  
replacement – custom made - repair

Possibility of certain adaptation according to  
your requests

### Safety

Auto- Lock system

Garantee more security

A chuck with several options for your safety  
& different types of locking system (p6)



The MBC safety chucks (Mechanism Blocking Control) were designed to achieve all your winding & unwinding operations. Its automatic locking system protects in the event of an accident. Discover all our designs and find the solution that best suits your needs.

## Patents MBC



### Easier maintenance

A chuck design to optimize your maintenance time.

Gain nearly 15 minutes on the change of your wear parts.

7 screws and a disassembly only by the front face !

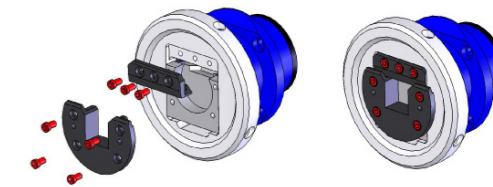

### Easier maintenance

Disassembly of steering wheel axis and the locking ball becomes simply as child's play.

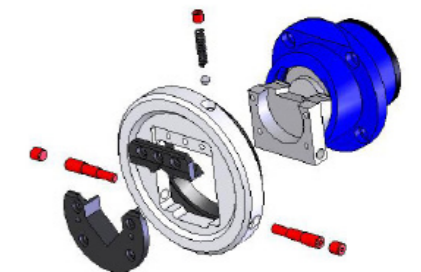

## Design

Design of the locking system made with a push button stronger, more secure, more ergonomic.

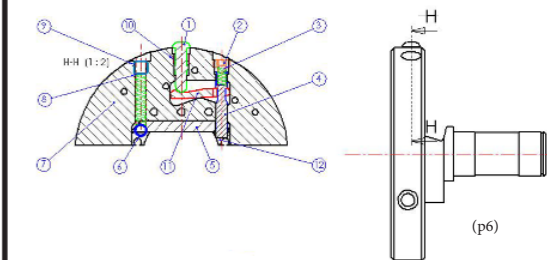

MODEL	REEL WEIGHT	TORQUE	SQUARE DIMENSION
14 – 20	150 kg	40 Nm	14 to 20 mm
18 – 25	400 kg	120 Nm	18 25 mm
20 – 30	800 kg	185 Nm	20 to 30 mm
30 – 40	1600 kg	350 Nm	30 to 40 mm
40 – 50	2850 kg	1 100 Nm	40 to 50 mm
50 – 80	7200 kg	2 350 Nm	50 to 80 mm
80 – 120	11 500 kg	9 000 Nm	80 to 120 mm
120 – 180	22 000 kg	20 000 Nm	120 to 180 mm
180 – 230	60 000 kg	40 000 Nm	180 to 230 mm

## Available goods

### Manual chuck

- Chuck with pivoting disc
- Chuck with slidding disc
- Translatory chuck, stroke 50 or 100 mm

### Pneumatical chuck

- Pneumatical chuck simple or double effects
- Pneumatical selcentring and multifunctions



# Choice of options :

## Choose your fixation type :

Foot (serie 150)
 

 Flange (serie 250)

## Choose your shaft end (coupled to a motorisation or a braking system) :

Chuck with shaft end = SFE/G
 

 Chuck without shaft end = SFE

## If with shaft end, choose the type best suited for your application :

STD
  MD
  BD
  AC
  Other applications on demand

## Choose your geometry :

WITHOUT wear part

Type A
  Type E
  Type B

WITH wear parts

Type APU
  Type EPU
  Type BPU
  Type AVPU
  Type AWPU

## Choose your anti opening system :

Type 1 - Left knurl
  Type 1 - Right knurl
  Type 2 - Push button

# Patent MBC : Chuck serie 2000

## Benefits

- Work at high speed
- No vibration
- Selfcentring
- Multifunction
- Axial adjustment

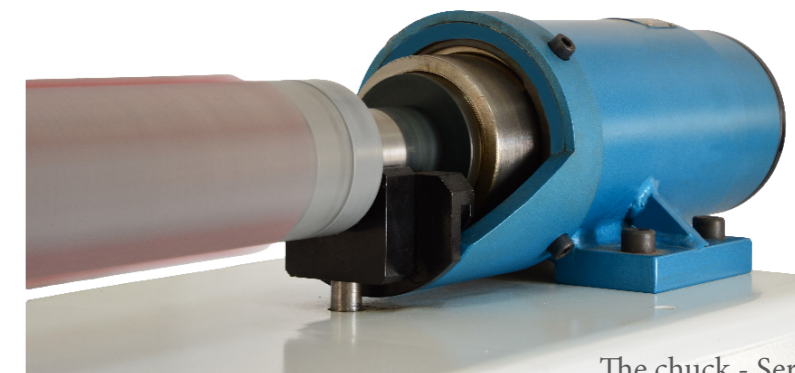

The chuck - Serie 2000 & 2100 is a pneumatical chuck that simplify your operation and improve your performance.

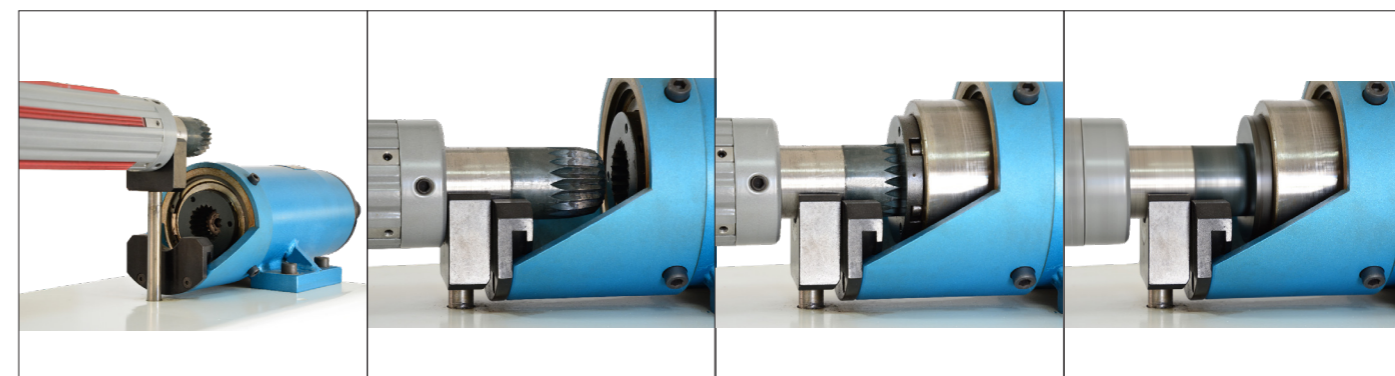

Step 1

Install your shaft on the support

Step 2

Start your pneumatical system

Step 3

Thanks to his conical tip, the Serie 2000 collects and center automatically the shaft. The double conical tip avoids damaging effects on the notched end.

Step 4

Start rotation. You have now a rotation with no vibration which allows the work at very high speed, in safer conditions, with better performances.

## Options available:

Smooth shaft support



Expansible head with shells



Shaft support with journal bearing



Expansible head with lugs



## Benefits



Made in France  
since 1983

Engineering Department  
Custom made - Repairs

Lightness : MBC Guttin  
thinks about your users !



R&D of a reinforced aluminium :  
+ 35 % load  
- 40% bending  
for an equal weight to a standard  
aluminium shaft

Choose your material :  
Aluminium - Steel,  
and only for shaft with lugs :  
Carbon - reinforced Aluminium

Choose your expansion :  
Rubber - Aluminium - Steel

Choose your expansion :  
With lugs or continuous fillets

Choose your shaft end :  
Square - triangle - double  
geometry or custom made.



Expandable airshafts allows the inside core  
to mold the shaft and to exert winding &  
unwinding operations.

Manufacturer, MBC offers expandable  
airshafts from  $\varnothing 1''$  (25.4 mm) up to  
 $\varnothing 35''$  (900 mm) and up to 9 m length.

We carry out the desire shaft end with all  
your specifications needed for your  
application.

## Patent MBC

Airshaft with lugs

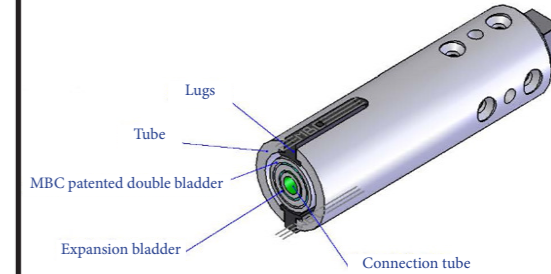

## Strengthness

Protection of the bladder kit with the  
«double skin».  
Unique & patented by MBC Guttin.



## Easier maintenance

Thanks to our double skin bladder, the  
lugs remain in place !

You save 45 minutes when changing the  
bladder kit.

## Design

Airshaft with continuous fillets

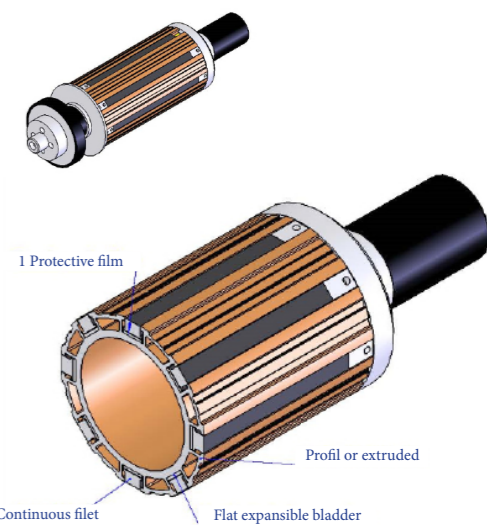

**Expandible head**

- Cantilevered work
- Rigidity & adaptability
- Stationary bar

**Sleeve**

- Quick use
- Change of  $\varnothing$  if desired
- Easily switch from  $\varnothing 74$  mm to  $\varnothing 150$  mm

**Airshaft with shells**

- Protects the final product
- Thin thickness cores
- Use without cores

**Design for paper industry**

- Locking & centring continuous filets
- Static balancing of the tube
- 1750 m/ min - up to 15 tons

**Friction bar**

- Multitracks
- Friction rings (balls or pawls)
- Equal tension on each spool



# SPREADER ROLLS

Get the best spreading system for your material.

A good spreading is obtained by the choice of an advisable material adapted to your product as well as the type of fold. MBC provides 4 kinds of spreader rolls, all specific to each application.

Curved spreader roll or Banana roll

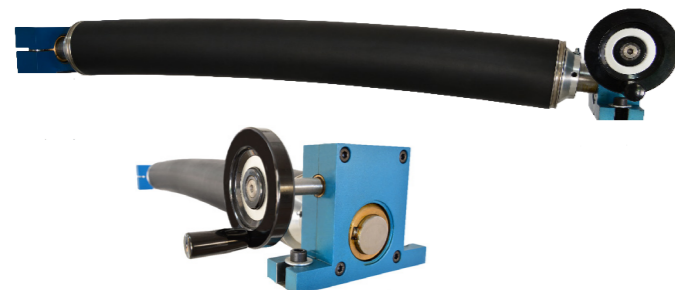

Spreader roll with stainless steel laths



## Benefits

- Operates by deformation
- The most polyvalent of our spreader rolls (moisture, corrosive..)
- Different kind of coating or fully made of stainless steel
- Fixed or variable curvature

## Benefits

- Operates by spreading
- Suitable for heavy and delicate materials
- Different kind of coating for the laths

Spreader rolls with ropes



## Benefits

- Operates by spreading
- Perfect for technical textiles & delicate materials
- Polyvalent (film, plastic...)
- Different kind of ropes

Spiral spreader rolls (machinated or add-on)

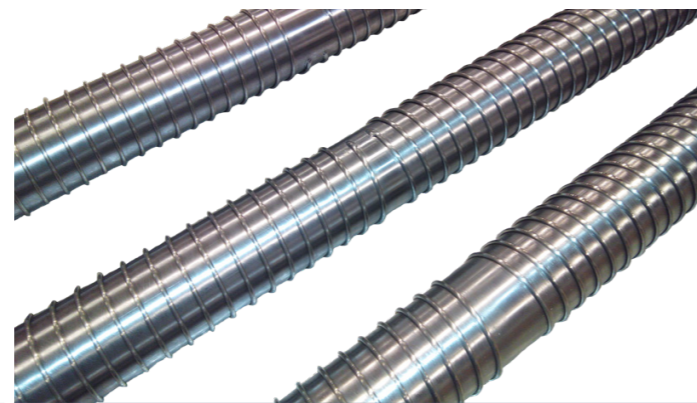

## Benefits

- Operates by spreading the material effortless
- To be mounted instead of guiding rolls
- Thickness & depth choices
- Available in aluminium, steel, stainless steel, rubber
- No maintenance

# BRAKES

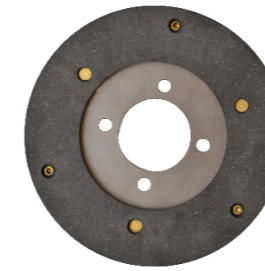

Manage the tension of your product thanks to our MBC braking system. At MBC we offer a ferrodo brake, manual or pneumatical, made in France, fitting all your applications.

Even more accuracy? We also have multi-piston and electrical brakes. Do not hesitate to contact us !

Power	∅A	L
40 Nm	145	100
70 Nm	220	100
480 Nm	300	100

Mono-disc

Power	∅A	L
90 Nm	145	125
180 Nm	220	125
900 Nm	300	125

Bi-disc

MANUAL BRAKE

MBC Guttin

Power	∅A	L
40 Nm	145	125
70 Nm	220	125
480 Nm	300	125

Mono-disc

Power	∅A	L
90 Nm	145	145
180 Nm	220	145
900 Nm	300	145

Bi-disc

PNEUMATICAL BRAKE

MBC Guttin

# Miscellaneous

- Anti-static Material
- Tension Control

Guiding roll



Support base axial and or radial adjustment for chuck

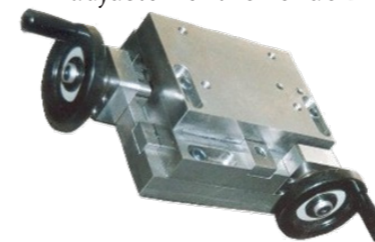

Mechanical head expansion with torque



Trolley and/or frame design



Mechano pneumatical or manual reel riser



Mechanical head with axial thrust

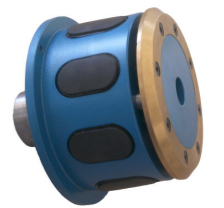

Shaft with bearing case for cantilevered unloading



Fiberglass Core

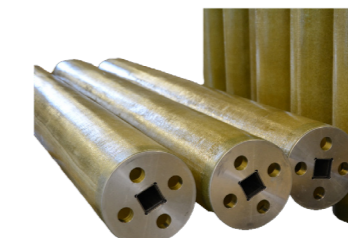

Aluminium locking cones







# GLOBAL PRESENCE



50 Route du Charmay - 38490 CHARANCIEU  
 Tél : + 33 (0) 4 76 32 07 82 - Fax : + 33 (0) 4 76 32 29 56  
 www.guttin.com - mbc@guttin.com

Management Fabrice & Stéphane GUTTIN	Sales Patrick CREUSET + 33 (0) 6 61 30 07 83	Administrative & Accounting Stéphane GUTTIN Marie -Blanche GUTTIN	Technical Manager Fabrice GUTTIN
Insides Sales France Isabelle LECUYER	Export Paloma OLAY		Engineering - Custom Service Julien GULLON
Company Founder & Consultant Christian GUTTIN			Quality & Production Manager Gérard REYNAUD

## — Our Worldwide Sales —

 <p>SWITZERLAND</p> <p>CORTECH AG Mr Sandro CORTESI</p> <p>(tel) 0041 62 752 20 84 (fax) 0041 62 752 23 69 info@cortechag.ch</p>	 <p>NETHERLANDS</p> <p>OPENSUPPLY B.V. Mr Erik FRANKE</p> <p>(tel) 0031 541 700 260 (fax) 0031 541 744 025 erik@opensupply.eu</p>	 <p>USA</p> <p>LOUIS P. BATSON Incorporated Mr Chuck WITHINGTON</p> <p>(tel) 001 864 242 5262 (fax) 001 864 271 4535 chuckw@lpbatson.com</p>	 <p>POLAND</p> <p>ANT MASCHINENHANDEL UG Mr Alex NITUSOV BERLIN</p> <p>(tel) 0049 30 985 984 26 0049 173 272 69 00 info@ant-germany.com</p>	 <p>CZECH REPUBLIC</p> <p>ANT MASCHINENHANDEL UG Mr Alex NITUSOV BERLIN</p> <p>(tel) 0049 30 985 984 26 0049 173 272 69 00 info@ant-germany.com</p>
 <p>NORTH GERMANY</p> <p>ANT MASCHINENHANDEL UG Mr Alex NITUSOV BERLIN</p> <p>(tel) 0049 30 985 984 26 0049 173 272 69 00 info@ant-germany.com</p>	 <p>SOUTH GERMANY</p> <p>Mr Juan Jose SANCHEZ KARLSRUHE</p> <p>(tel) 0049 176 87 74 38 jsanchez@guttin.com</p>	 <p>SPAIN</p> <p>BARBANY Maquinaria Textil Mr Rodolf BARBANY</p> <p>(tel) 0034 93 450 16 87 (fax) 0034 93 347 84 54 info@barbany.com</p>	 <p>AUSTRIA</p> <p>HENNLICH Gmbh &amp; Co KG Mr Andreas HOCHHOLD</p> <p>(tel) 0043 7712 3163 0 (fax) 0043 7712 3163 24 andreas.hochhold@hennlich.at</p>	